

### Abstract

A novel PV based Dynamic voltage restorer (DVR) with fuzzy controller installed between the supply and sensitive load to protect sensitive devices in voltage disturbances. DVR should inject voltage and active power from DVR to distribution system during voltage disturbances. Inject voltage taken from solar PV panel. In this paper new control method and minimal energy taken for DVR is proposed by combing with fuzzy logic.

**Keyword:** Power quality; dynamic voltage restore; control strategies; minimal energy control.

### Introduction

Voltage sag and swell are two most importance term in power quality (PQ) problems that produced almost 80% of the distribution system PQ problem[1]. According to the IEEE standard, voltage sag is decrease of 0.1 to 0.9 p.u in the rms voltage level at the system frequency and with duration of half cycle to 1 min . voltage sag of down to 70% are much more common then complete outage. Short circuits, starting large motors, sudden changes of load, and energization of transformer are the main cause of voltage sag. Considering the use of sensitive device in modern industries. Different methods of compensation of voltage sags have been used[4]. One of those method is using DVR with energy storage can be used to control power quality problems. A DVR is basically a controlled voltage source installed between the supply and a sensitive load. It injects voltage on the distribution system to compensate any disturbance after load side. The compensation capacity of a particular DVR depends on the maximum voltage injection ability and active power which can be supplied by the DVR[5]. DVR could maintain load voltage unchanged during any kind fault in use of energy storage devices. Battery, super conducting magnetic energy storage system (SEMES) is required to apply active power to DVR at fault time[7]. So this storage energy limitation necessary to minimize energy injection from DVR. In this paper new minimal energy injection technique of restore voltage sage are discussed.

### DVR Components

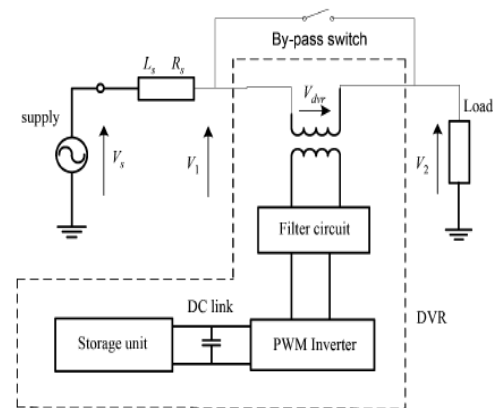

**Fig1. Typical DVR connected distribution system.**

A typical DVR-connected distribution system is shown in (Fig. 1), where the DVR consists of a voltage-source inverter, series-connected injection transformer, an inverter output filter, and an energy storage device that is connected to the dc link. Voltage source inverter can be controlled three phase injection transformer[8]. Before injecting the inverter phase output to the voltage, it must be filtered so that harmonics due to switching function in the inverter are eliminated. The injection transformer will be connected in parallel with a bypass switch (Fig. 1). When there is no disturbance in voltage, the injection transformer will be short circuited by this switch to minimize losses and maximize cost effectiveness. Also, this switch can be in the form of two parallel thrusters, as they have high on and off speed. A financial assessment of

Voltage sag events and use of flexible ac transmission systems (FACTS) devices, such as DVR, to mitigate them is provided. It is obvious that the flexibility of the DVR output depends on the switching accuracy of the pulse width modulation (PWM) scheme and the control method. The PWM generates sinusoidal signals by comparing a sinusoidal wave with a saw tooth wave and sending appropriate signals to the Inverter switches.

**DVR Operational Principle**

The DVR system shown in Fig. (1) Controls the load voltage by injecting an appropriate voltage phasor (VDVR) in series with the system using the injection series transformer [9]. In most of the sag compensation techniques, it is necessary that during compensation, the DVR injects some active power to the system. Therefore, the capacity of the storage unit can be a limiting factor in compensation, especially during long-term voltage sags.

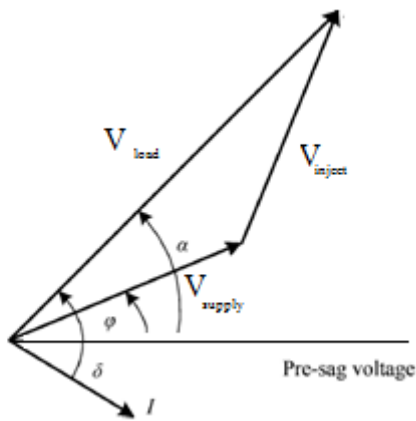

Fig . 2 . phasor diagram of the electrical conditions during a voltage sag

The phasor diagram in Fig.( 2) shows the electrical conditions during voltage sag, where, for clarity only one phase is shown. the operators  $I$ ,  $\delta$ ,  $\phi$  are the load current, the load power factor angle, and the voltage phase advance angle, respectively (13) . It should be noted that in addition to the in-phase injection technique. One of the advantages of this method over the in-phase method is that less active power should be transferred from the storage unit to the distribution system. This results in compensation for deeper sags or sags with longer durations. Due to the existence of semiconductor switches in the DVR inverter, this piece of equipment is nonlinear. However, the state equations can be liberalized using linearization techniques. The dynamic characteristic of the DVR is influenced by the filter and the load. Although the modeling of the filter (that usually is a simple LC circuit) is easy to do, the load modeling is

not as simple because the load can vary from a linear time invariant one to a nonlinear time-variant one. In this paper, the simulations are performed with two types of loads: 1) a constant power load and 2) a motor load

**PRE-SAG Compensation Method**

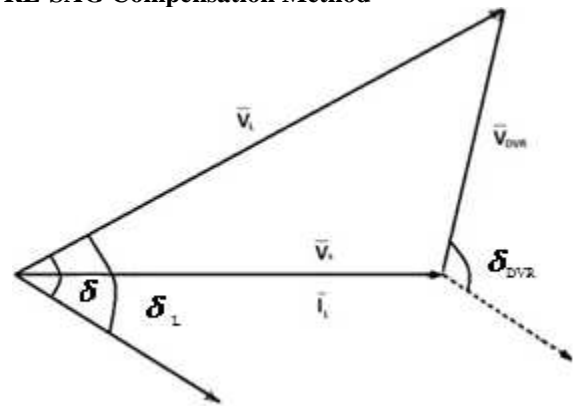

Fig 3. Pre-sag compensation method

In this fig (3), compensation takes the DVR injected voltage is different between load voltage and supply voltage in fault condition. In pre-sag condition, DVR injected to compensated voltage magnitude and phase angle but in this method main drawback is it's not controlled active power.

$$|v_{DVR}| = |v_s| - |v_l| \tag{1}$$

$$\delta_{DVR} = \tan^{-1} \left[ \frac{v_1 \sin \delta_1}{(v_1 \cos \delta_1 - v_s \cos \delta_2)} \right] \tag{2}$$

**IN-Phase Compensation Method**

In this method DVR injected voltage magnitude is compensation. DVR injected voltage is in phase to the fault supply voltage so that reason minimized the injected voltage from DVR and reduced the DC store capacity. In this method should DVR injected only pre sag voltage .mostly used in phase compensation is un sensitive loads but this method main drawback is its intentioned more active power

$$V_{inj} = V_{DVR} \tag{3}$$

$$|V_{inj}| = |v_{sag}| - |v_{load}| \tag{4}$$

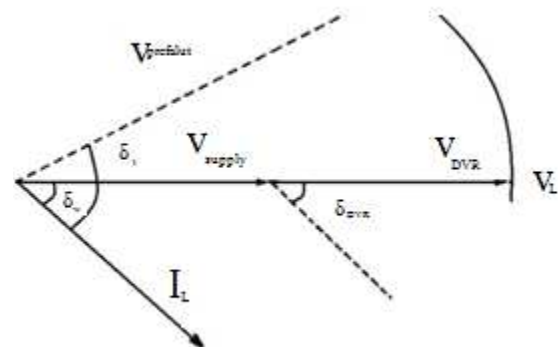

**Fig 4. In-phase compensation method Minimal Energy Technique**

Above two conventional methods are DVR injected voltage  $V_{dvr}$  have more active power so reduced that power due to limited DC storage capacity . in this below diagram for minimal energy technique, load current perpendicular to the injected voltage .now  $v_{dvr}$  injected active power is zero , more reactive power will be injected . in this paper improve to the reduced active power.

$$\alpha = \delta + \frac{\pi}{2} - \phi \quad (5)$$

$\delta$  is calculated given bellow equation

$$\delta = -\cos^{-1} \left[ \frac{V_s}{V_L \cdot \cos(\phi)} \right] + \phi \quad (6)$$

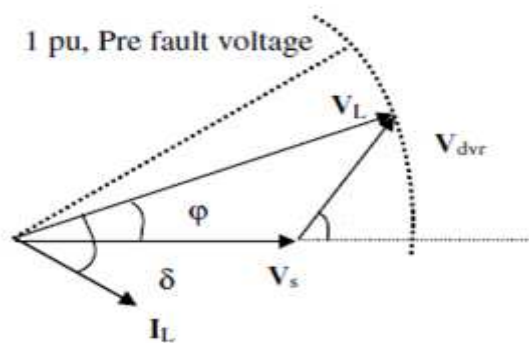

**Fig 5. Phasor diagram of minimal energy technique**

if supply voltage satisfy the bellow condition than the value of  $\delta$  is feasible

$$V_s \geq V_L \cos(\phi) \quad (7)$$

In above equations (7) is determine the sag level is shallow sag or deep sag. Deep sag means in above equations is equal .if the above equations is in equals means the sag is shallow sag. in shallow sag means DVR injected voltage is equal to the zero if deep sag means DVR injected voltage not equal to the zero. It should injected voltage.

**Suggested Control Strategy**

In this previous section injection active power  $P_{DVR}$  is zero at shallow sag. when deep sag is occurs the  $P_{DVR}$  is not equal to the zero in figure (6) supply voltage  $V_s$  and the load current increases it affected the active power and  $\beta$  values. it result to become increases to the above two values. The relationship between the active

power and DVR injected voltage. Show in the figure(6) with power factor 0.8 p.u.

$P_{dvr}$  injected power value is zero between sag value is 0 to 2 p.u .in this case  $P_{dvr}$  is negative side so more active power not required because no economical advantages. In consensual method the reactive power is small active power is high but minimum injection method active power injected small level and reactive power will be high. In this paper will be improved the minimum energy injection . bellow diagram the relationship between injection active power  $P_{dvr}$  and inject active power in balanced 3 $\phi$  voltage sag.

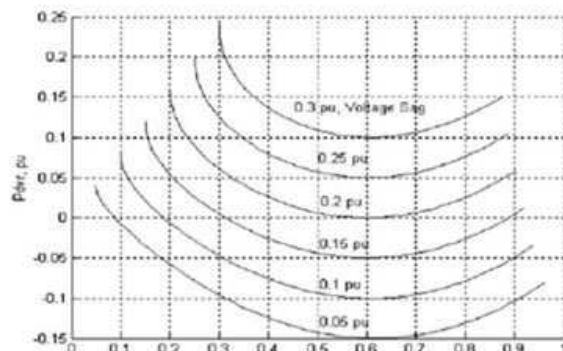
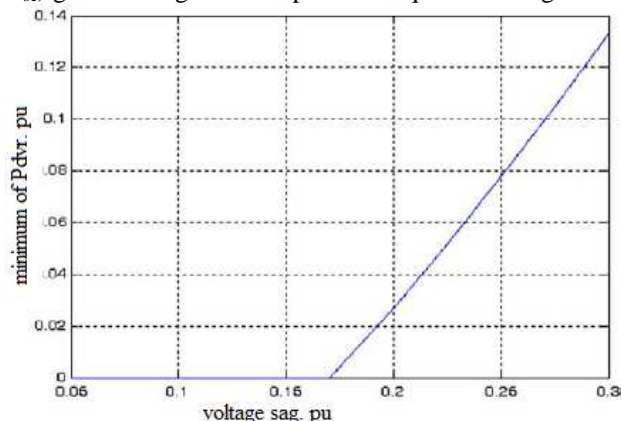

**Fig 6 injected active power vs injected voltage**

Negative  $P_{DVR}$  value of minimum injection active power is zero because not give economical advantages of due to limited storage capacity. The positive  $P_{dvr}$  value side of minimum active power will be injected .this power value estimated given bellow equation

$$P_{dvr} = (-0.1765 + 1.0325V \text{ sag}) \quad (7)$$

The voltage sags mentioned earlier were balance three-phase. For unbalance voltage sages, the three-phase instantaneous values of  $V_s$ , i.e., ( $V_{sa}$ ,  $V_{sb}$ ,  $V_{sc}$ ) generate negative and positive sequence voltages.



**Fig. 7. Minimum injected active power**

The output  $V_{dvr,ref}$  and  $V_{drq}$  value we get in conversion use park transformation from the 3phase load (abc) voltage frame to the dq reference  $V_{Ld}, V_{Lq}$  output apply to the bellow math function

$$V_{Lm} = \frac{\sqrt{(V_{Ld})^2 + (V_{Lq})^2}}{V_{base}} \quad (8)$$

Also input supply voltage ( $V_{sa}, V_{sb}, V_{sc}$ ) apply to the abc to dq transmission the output we get  $V_{sd,dc}, V_{sq,dc}$

Where T is

$$T = \begin{bmatrix} \cos(\omega t) & \cos(\omega t - 2\pi/3) & \cos(\omega t + 2\pi/3) \\ \sin(\omega t) & \sin(\omega t - 2\pi/3) & \sin(\omega t + 2\pi/3) \end{bmatrix} \quad (10)$$

Output we will get  $V_{Lm,pu}$ . this value compare to the  $V_{Lm,ref,pu}$  using comparator . the error signal applied to the fuzzy logic controller

In this project the compensation of load voltage for unbalance voltage sags, DVR Injects DC component of active power,  $P_{dvr, dc}$  that restores fundamental components Of voltage sags and in the same time injects

AC component of active power,  $P_{dvr, ac}$  that restores negative sequence components of voltage sags active power  $P_{dvr, dc}$  can be calculated as follows:

$$P_{dvr,dc} = V_{dvd,dc} I_d + V_{dvrq,dc} I_q \quad (11)$$

where

$$V_{dvr,dc} = V_{ld} - V_{sd,dc} \quad (12)$$

$$V_{dvrq,dc} = V_{lq} - V_{sq,dc} \quad (13)$$

The per unit magnitude of fundamental components of left-hand side voltage of DVR  $V_{sm, pu}$  can be obtained by the following equation:

$$V_{Lm} = \frac{\sqrt{(V_{Ld})^2 + (V_{Lq})^2}}{V_{base}} \quad (14)$$

The,  $P_{dvr, dc, ref}$  and the feedback difference between reference values value,  $P_{dvr, dc}$  passes through the fuzzy controller and the output of the fuzzy controller is added to the q axis AC component of  $V_s$ .

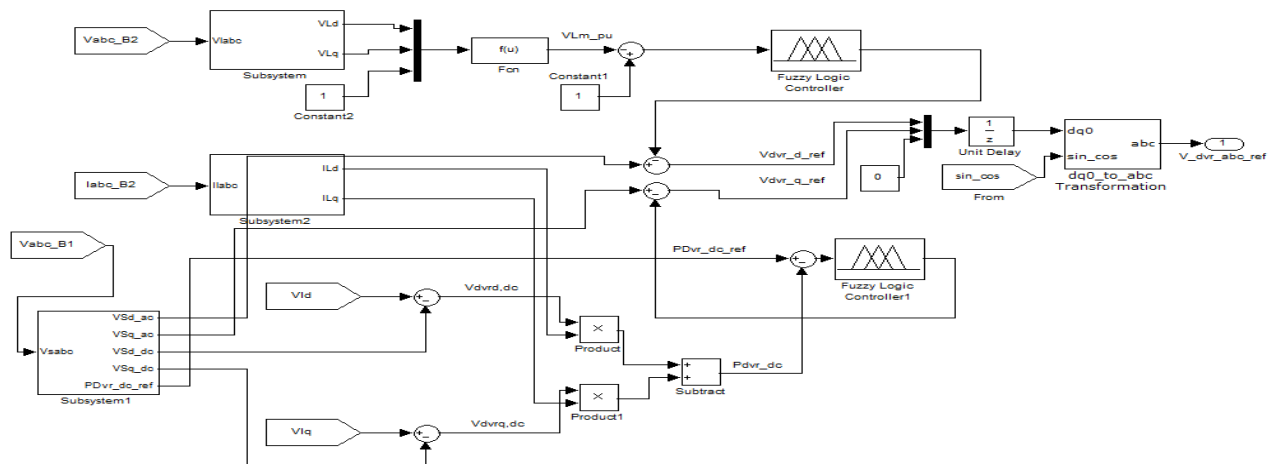

Fig 8 The Suggested Control

**Simulation Results**

System shown in fig (8) has been modeled by PSCAD/EMTDC to study the efficiency of suggested control strategy. The system parameters are listed in table 1. It is assumed that the voltage magnitude of the load bus is maintained at 1 pu during the voltage sag conditions. The results of the most important simulations are represented in Figs. 8.

Table 1 Case study parameter

parameter	value
Load voltage	400 v
Load power	125 kva

Load power factor	0.8
Base power	125 kva
Energy store value	120 v
Ls	1mh
Rs	0.07 ohm
Cs	300µf

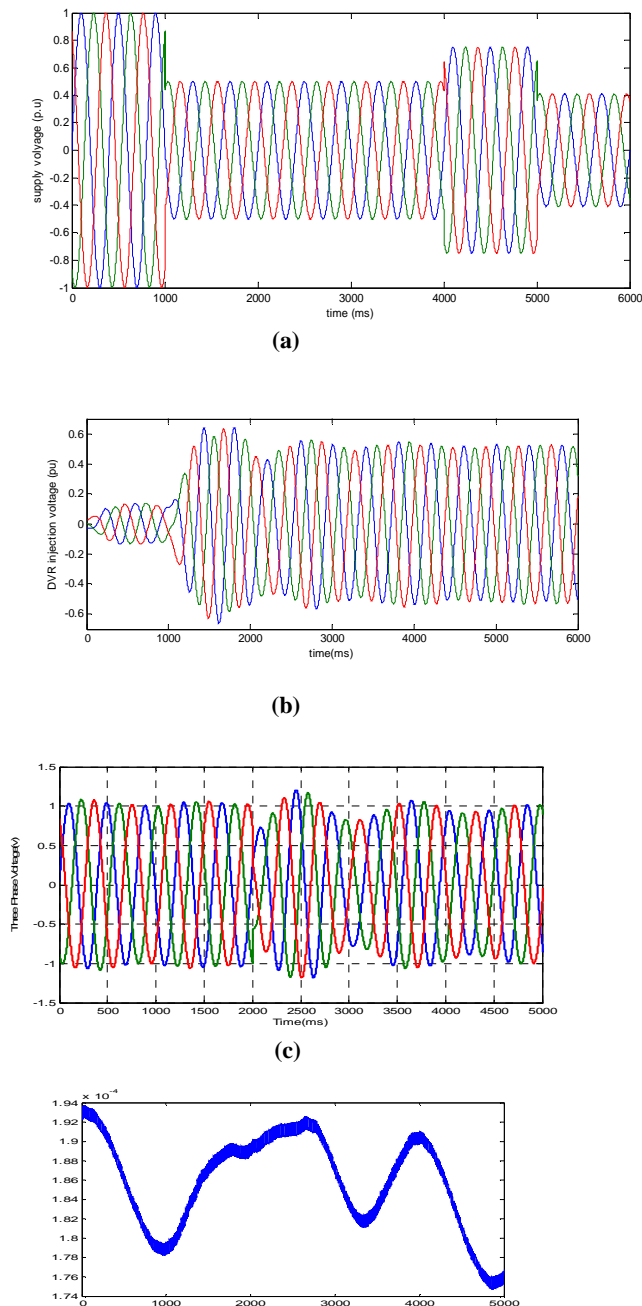

Fig .8. (a) supply voltage  $V_s$ , (b) injected voltage ( $V_{dvr}$ ), (c) load voltage ( $V_l$ ), (d) DC component of injected active power, ( $P_{dvr,dc}$ )

The three-phase instantaneous values of DVR left hand side voltage,  $V_s$ , i.e., ( $V_{sa}, V_{sb}, V_{sc}$ ), injected voltage,  $V_{dvr}$ , load voltage,  $V_L$  (or  $V_{La}, V_{Lb}, V_{Lc}$ ) and DC component of injected active power,  $P_{dvr, dc}$  have been shown in Fig.8(a), (b), (c) and (d) for a case with a 0.146 pu balance three-phase voltage sag which has

happened at  $t = 0.7$  s. In this case DVR works in the suggested control strategy mode.

### Conclusion

In order to compensate voltage sag it is possible to use dynamic voltage restorer(DVR) with fuzzy logic control in distribution system for a sensitive load. In this paper the control strategies for the compensation of the supply voltage sag is presented. In addition, a new concept of restoration technique is proposed to inject minimum energy in unbalance sags. Proposed control method makes zero injection power during shallow sag and controls DVR so that injection of power is minimized during deep sag. Simulation results carried out by the PSCAD/EMTDC shows that the proposed method can minimize the injected active power of DVR for a specific apparent power.

### References

- [1] A.Choi., B.H. Li, D.M. Vilathgamuwa, (2010) Design and analysis of the inverter-side filter used in the dynamic voltage restorer, *IEEE Transactions on Power Delivery* 17 (3).
- [2] A.Ramasamy, V.K. Ramachandaramurthy, R.K. Iyer, Z.L. Liu,( 2007). "Control of dynamic voltage restorer using TMS320F2812", *Electrical Power Quality and Utilization Conference*, pp: 1-6.
- [3] A. Ghosh, . and G. Ledwich, (2010). Compensation of Distribution System Voltage Using DVR, *IEEE Trans on Power Delivery*, 17(4): 1030-1036. Muni
- [4] C. Zhan, A. Arulampalam, N. Jenkins, (2009) Four-wire dynamic voltage restorer based on a three dimensional voltage space vector PWM algorithm, *IEEE Transactions on Power Electronics* 18 (4).
- [5] G. Venkataramanan, and M. Illindala, (2006). "Operation and control of a dynamic voltage restorer using transformer coupled H-bridge converters." *IEEE Trans. Power Electron.*, 21(4): 1053-1061.
- [6] H. Kim, Minimal energy control for a dynamic voltage restorer, in: *Proceedings of PCC Conference, IEEE 2002*, vol. 2, Osaka (JP), pp. 428-433.
- [7] H. Ding, S. Shuangyan, X.z. Duan, G. Jun, A novel dynamic voltage restorer and its unbalanced control strategy based on space vector PWM, *Electrical Power and Energy Systems* 24 (2002) 693-699.124 M.R. Banaei et al. / *Simulation Modelling Practice and Theory* 14 (2006) 112-125 52
- [8] J. Gu, D. Xu, H. Liu, M. Gong, Unified power quality conditioner (UPQC): the principle,

- control and application, in: Power Conversion Conference, IEEE 2002, vol. 1, PCC-Osaka, pp. 80–85.
- [9] X. Lei, D. Retzmann, M. Weinhold, Improvement of power quality with advanced power electronic equipment, Electric Utility Deregulation and Restructuring and Power Technologies, City University, London, April 4–7, IEEE 2000.
- [10] I.-Y. Chung, D.-J. Won, S.-Y. Park, S.-I. Moon, J.-K. Park, The DC link energy control method in dynamic voltage restorer system, Electrical Power and Energy Systems 25 (2003) 525–531.
- [11] V.K. Ramachandramurthy, C. Fitzner, A. Arulampalam, C. Zhan, M. Barnes, N. Jenkins, Control of a battery supported dynamic voltage restorer, IEE Proceedings-C Generation Transmission and Distribution 149 (5) (2002).
- [12] Manitoba HVDC Research Center, PSCAD/EMTDC: Electromagnetic transients program including dc systems, 1994.
- [13] K. Agileswari, .Ramasamy, Rengan Krishnan Iyer, Dr. R.N. Mukerjee, Dr. Vigna K. Ramachandramurthy, 2005. “Dynamic Voltage Restorer for voltage sag compensation”, IEEE PEDS, pp: 1289-1293
- [14] S. Venkateshwarlu, H. V. Makthal, P. J. Hyderabad, 2004. “Review of dynamic voltage restorer for power quality improvement”, IEEE Industrial Electronics Society, 1: 749-754. Wang,
- [15] Li, B.H., S.S. Choi and D.M.Vilathgamuwa, 2001. “Design consideration of the line side filter used in the dynamic voltage restorer,” *IEE Proc. -Generation Transmission Distribution*, 148(1).